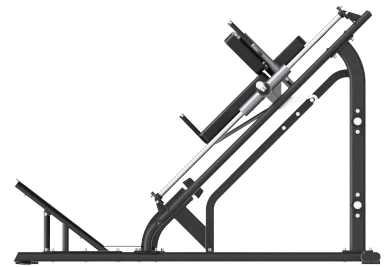
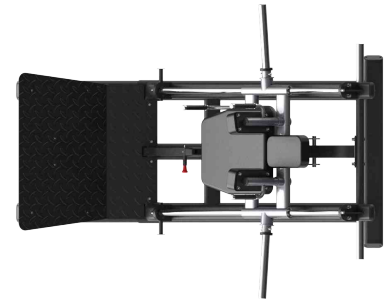

SH PLATE LOADED SERIES**SH036 - HACK SQUAT****PRODUCT OVERVIEW**

The SH036 is a premium plate-loaded strength training machine specifically designed for lower body development. With a sleek, modern design and solid structural integrity, it is ideal for commercial gyms and high-end personal training studios.

Equipped with a precision dual-axis linear bearing system, the machine ensures exceptionally smooth and stable squat motion, delivering a natural movement path and precise force output.

The shoulder pads feature high-resilience material and an ergonomic tilt to relieve pressure on the shoulders, while the wide backrest and contoured headrest offer secure body support for enhanced comfort and safety during training. A prominently placed safety hook control lever allows for effortless engagement, and the five-level adjustable bottom stop adapts to users of different heights and squat depths. The oversized anti-slip footplate, designed with dual-angle positioning, accommodates various stances and ankle flexion angles, improving overall training effectiveness and accessibility.

SPECIFICATIONS & KEY FEATURES

Specifications

Dimension:	2225*1786*1578mm
Net Weight:	250kg
Max Load Capacity:	300kg[2x150kg]
Main Frame Tubing:	PT60x120x2.5
Standard Color Scheme:	SH Series standard color scheme

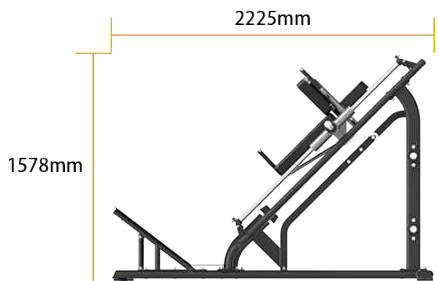
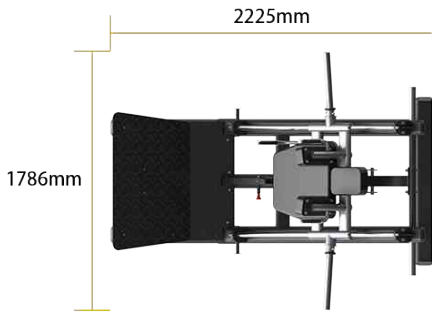
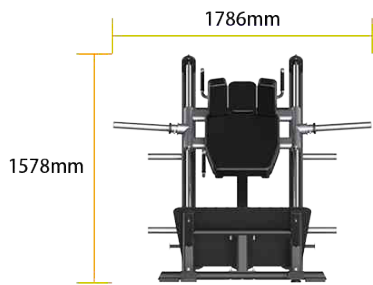

Product Features



Dual-Axis Rail System for Smooth Stability

The high-precision linear guide system ensures consistent and fluid motion, minimizing vibration and jamming during heavy squat sessions.

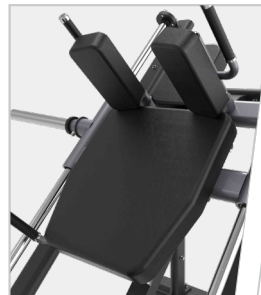

Ergonomic Support for Comfort & Alignment

Shoulder pads, backrest, and headrest are ergonomically contoured to fit the natural curves of the body, reducing pressure and enhancing stability throughout the movement.



Adjustable Safety Stops for Secure Range Control

An easy-to-reach safety hook control lever and 5-level adjustable bottom stop provide flexible depth options while protecting users from overextension.

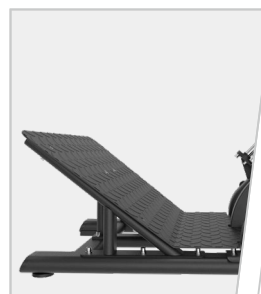

Oversized Anti-Slip Footplate for Versatile Positioning

The dual-angle footplate supports a wide range of foot placements and ankle mobility, accommodating diverse user needs and maximizing glute and quad engagement.